

D-SUB M6.3 T09HU 3.2B2 TY BK

Weidmüller Interface GmbH & Co. KG

Klingenbergstraße 26

D-32758 Detmold

Germany

www.weidmueller.com

Product image

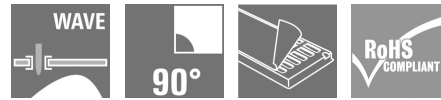

The product range encompasses the following designs:

- 90°, lying (horizontal) and 180°, standing (vertical)
- Flange design as drilled hole, UNC 4-40 threaded nut and UNC 4-40 threaded bolt
- Stamped contacts (Rated current: 3 A)
- THT soldering process
- Wide range of different design types, also with snap-on clip
- Packed in tray (TY)
- Extended temperature range of -55 °C to $+85\text{ °C}$ for maximum performance
- Design in accordance with IEC 60807-3 (IEC 807-3) and DIN 41652

General ordering data

Version	OMNIMATE Data - D-SUB connector, male header, Thread-nut UNC 4-40, Snap-on clip, THT solder connection, Pitch in mm (P): 2.77 mm, Number of poles: 9, $\geq 50\text{ }\mu\text{m Ni}$ / $\geq 1\text{ }\mu\text{m Au}$, 500, PBT glass fibre reinforced UL 94 V-0, black, Tray (manual assembly)
Order No.	2626680000
Type	D-SUB M6.3 T09HU 3.2B2 TY BK
GTIN (EAN)	4050118663624
Qty.	90 pc(s).
Packaging	Tray (manual assembly)

Creation date December 1, 2023 1:16:55 PM CET

D-SUB M6.3 T09HU 3.2B2 TY BK**Weidmüller Interface GmbH & Co. KG**

Klingenbergstraße 26

D-32758 Detmold

Germany

www.weidmueller.com

Technical data**Dimensions and weights**

Depth	20.9 mm	Depth (inches)	0.823 inch
Height of lowest version	12.55 mm	Width	30.81 mm
Width (inches)	1.213 inch	Net weight	7.544 g

System specifications

Model	Plug	
Mounting onto the PCB	THT solder connection	
Number of poles	9	
Outgoing elbow	90°	
Pitch in inches (P)	0.109 inch	
Pitch in mm (P)	2.77 mm	
Plugging cycles	500	
Product family	OMNIMATE Data - D-SUB connector	
Shield surface	tinned	
Shielding material	Steel	
Side termination, characteristic	Thread-nut UNC 4-40, Snap-on clip	
Solder eyelet hole diameter (D)	1 mm	
Solder pin dimensions	Octagonal	
Solder pin length (l)	3.2 mm	
Solder pin length tolerance	Lower tolerance with prefix (reveals minimum)	-0,25
	Upper tolerance with prefix (reveals maximum)	+0,25
	Tolerance, unit	mm
Solder pin length tolerance	+0,25 / -0,25 mm	
Soldering process	Manual soldering, Wave soldering	
Tolerance of solder pin position	± 0.1 mm	
Type of connection	Solder connection	

Electrical properties

Dielectric strength, contact / contact	1000 V AC	Rated current	3 A
Rated voltage	250 V	Volume resistance	≤20 mΩ

Material data

Insulating material	PBT glass fibre reinforced UL 94 V-0	Colour	black
Colour chart (similar)	RAL 9011	UL 94 flammability rating	V-0
Contact base material	Phosphorus bronze	Contact surface	Au (Gold)
Layer structure of solder connection	≥ 50 μ" Ni / ≥ 1 μ" Au	Layer structure of plug contact	≥ 50 μ" Ni / ≥ 1 μ" Au
Storage temperature, min.	-20 °C	Storage temperature, max.	85 °C
Operating temperature, min.	-55 °C	Operating temperature, max.	105 °C

Packing

Packaging	Tray (manual assembly)	VPE length	295 mm
VPE width	209 mm	VPE height	23 mm

D-SUB M6.3 T09HU 3.2B2 TY BK

Weidmüller Interface GmbH & Co. KG
 Klingenbergstraße 26
 D-32758 Detmold
 Germany

www.weidmueller.com

Technical data**Classifications**

ETIM 6.0	EC002637	ETIM 7.0	EC002637
ETIM 8.0	EC002637	ETIM 9.0	EC002637
ECLASS 9.0	27-44-04-02	ECLASS 9.1	27-44-04-02
ECLASS 10.0	27-44-04-02	ECLASS 11.0	27-46-02-01
ECLASS 12.0	27-46-02-01	ECLASS 13.0	27460201

Environmental Product Compliance

REACH SVHC Lead 7439-92-1

Approvals

Approvals



ROHS	Conform
UL File Number Search	UL Website
Certificate No. (UR)	E92202

Downloads

Engineering Data	CAD data – STEP
Catalogues	Catalogues in PDF-format

Data sheet

D-SUB M6.3 T09HU 3.2B2 TY BK

Weidmüller Interface GmbH & Co. KG
Klingenbergstraße 26
D-32758 Detmold
Germany

www.weidmueller.com

Drawings

Product image

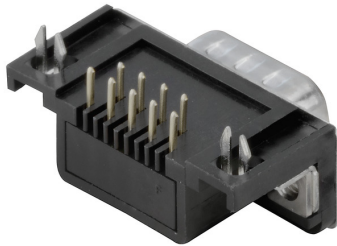

D-SUB M6.3 T09HU 3.2B2 TY BK

Weidmüller Interface GmbH & Co. KG
 Klingenbergstraße 26
 D-32758 Detmold
 Germany

www.weidmueller.com

Drawings

Packaging drawing

Scale	Free
TOLERANCE	
X.	±0.38
X.X	±0.25
X.XX	±0.13
DIM	TOL
X.°	±3°
X.X°	±1.0°
Angle	TOL

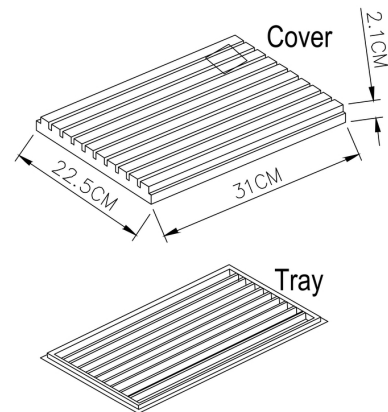

Dimensional drawing

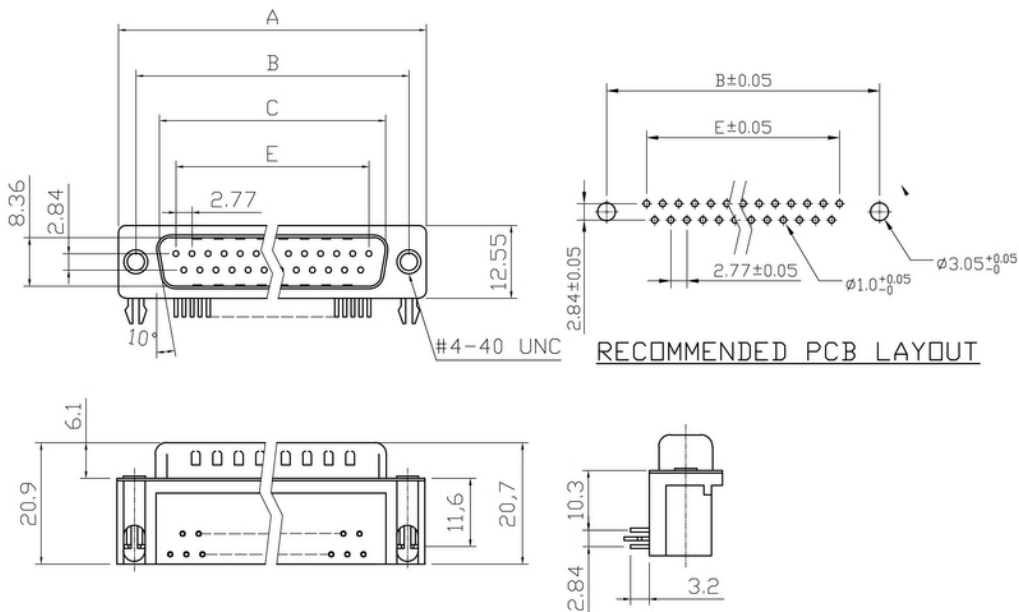

Dimensions				
Positions	A	B	C	E
9	30.81	24.99	16.92	11.08
15	39.20	33.30	25.25	19.39
25	53.05	47.04	38.96	33.24
37	69.40	63.50	55.42	49.86

Unit: mm

Recommended wave soldering profiles

Weidmüller Interface GmbH & Co. KG
 Klängenbergstraße 16
 D-32758 Detmold
 Germany
 Fon: +49 5231 14-0
 Fax: +49 5231 14-292083
 www.weidmueller.com

Single Wave:



Double Wave:



Wave soldering profiles

Wired connection elements should be processed in accordance with the DIN EN 61760-1 standard. We have included two recommendations for practical wave soldering profiles, with which Weidmüller PCB terminals and connectors are qualified.

When choosing a suitable profile for your application, the following factors also need to be considered:

- PCB thickness
- Proportion of Cu in the layers
- Single/double-sided assembly
- Product range
- Heating and cooling rates

The single and double wave profiles each indicate the recommended operating range, including the maximum soldering temperature of 260°C. In practice, the maximum soldering temperature is quite often well below the above maximum profile.