

## RJ45G1 R12D 3.2E4YG/YG RL

**Weidmüller Interface GmbH & Co. KG**  
Klingenbergstraße 26  
D-32758 Detmold  
Germany

www.weidmueller.com

### Product image



RJ45 transmitter sockets (magnetics) for gigabit applications (1000 base-T) with integrated compensation actively counteracts inductive and capacitive couplings and saves space on the PCB.

The product range encompasses the following designs:

- 90°, lying (horizontal) and 180°, standing (vertical)
- latch up / latch down
- THT, THR or SMD soldering processes
- Wide range of different design types, also with integrated LEDs and shield contact tabs
- Transmission rates of up to 1 Gbps
- Packed either in a tray (TY) or on a roll (tape-on-reel, RL)
- Compatible with modular RJ45 connector according to ANSI / TIA-1096-A and IEC 60603
- Dielectric strength  $\geq 1500$  V AC RMS (2250 V AC peak value) according to IEEE 802.3
- Dielectric strength  $\geq 1500$  V AC (peak value) or  $\geq 1500$  V DC according to IEC 60603
- Compliance with IEEE 802.3 requirements (1000Base-T, 1 Gbps, IEEE 802.3ab or 100Base-Tx, 100 Mbps, IEEE 802.3u)

Properties and advantages:

- Extended temperature range of  $-40$  °C to  $+85$  °C for maximum performance
- Reinforced gold layer ( $30\mu$ ) for improved corrosion protection

- At least 0.3mm stand-off ensures a perfect soldering result

### General ordering data

Version	PCB plug-in connector, RJ45 jacks transformer, 1000 Mbps, THT/THR solder connection, 90°, Latch option: bottom, Shield tabs: 6 tabs, 30...80 $\mu$ Ni / $\geq 30$ $\mu$ Au, LED: Yes, Green/yellow, Green/yellow, Number of poles: 8, Tape
Order No.	<a href="#">2036510000</a>
Type	RJ45G1 R12D 3.2E4YG/YG RL
GTIN (EAN)	4050118408409
Qty.	180 pc(s).
Packaging	Tape

Creation date December 1, 2023 12:28:40 PM CET

## RJ45G1 R12D 3.2E4YG/YG RL

**Weidmüller Interface GmbH & Co. KG**

Klingenbergstraße 26

D-32758 Detmold

Germany

www.weidmueller.com

## Technical data

### Dimensions and weights

Depth	21.5 mm	Depth (inches)	0.846 inch
Height	16.9 mm	Height (inches)	0.665 inch
Height of lowest version	13.6 mm	Width	31.2 mm
Width (inches)	1.228 inch	Net weight	7.675 g

### System specifications

Colour of left LED	Green/yellow	Colour of right LED	Green/yellow
LED	Yes	Latch option	bottom
Mounting onto the PCB	THT/THR solder connection	Number of poles	8
Number of solder pins per pole	1	Outgoing elbow	90°
Performance-Category	1000 Mbps	Pitch in inches (P)	0.05 inch
Pitch in mm (P)	1.27 mm	Plugging cycles	750
Product family	OMNIMATE Data - RJ45 transformer jack	Protection degree	IP20
Shield surface	nickel-plated	Shield tabs	6 tabs
Shielding	Yes	Shielding material	Brass
Solder eyelet hole diameter (D)	0.9 mm	Solder eyelet hole diameter tolerance (D)± 0.1 mm	
Solder pin dimensions	0.40 x 0.30 mm, LED pins = 0.50 x 0.50 mm	Solder pin length (l)	3.2 mm
Soldering process	Reflow soldering, Manual soldering, Wave soldering	Tolerance of solder pin position	± 0.1 mm
Transmission rate	1000 Mbps	Type of connection	Solder connection
Wiring	10-wire		

### Electrical properties

Dielectric strength, contact / contact	1000 V DC	Dielectric strength, contact / shield	1500 V DC
Rated current	1.5 A	Rated voltage	125 V

### Material data

Insulating material	PA 9T	Colour	black
Colour chart (similar)	RAL 9011	Insulating material group	II
Comparative Tracking Index (CTI)	≥ 500	Moisture Level (MSL)	1
UL 94 flammability rating	V-0	Contact base material	Phosphorus bronze
Contact surface	Gold over nickel	Layer structure of plug contact	30...80 μ" Ni / ≥ 30 μ" Au
Storage temperature, min.	-40 °C	Storage temperature, max.	85 °C
Operating temperature, min.	-40 °C	Operating temperature, max.	85 °C

### Packing

Packaging	Tape	VPE length	360 mm
VPE width	352 mm	VPE height	132 mm
Tape reel diameter ø (A)	330 mm	Surface resistance	Rs = 10 <sup>9</sup> - 10 <sup>12</sup> Ω

### Classifications

ETIM 6.0	EC002637	ETIM 7.0	EC002637
ETIM 8.0	EC002637	ETIM 9.0	EC002637
ECLASS 9.0	27-44-04-02	ECLASS 9.1	27-44-04-02
ECLASS 10.0	27-44-04-02	ECLASS 11.0	27-46-02-01
ECLASS 12.0	27-46-02-01	ECLASS 13.0	27460201

Creation date December 1, 2023 12:28:40 PM CET

## RJ45G1 R12D 3.2E4YG/YG RL

**Weidmüller Interface GmbH & Co. KG**  
Klingenbergstraße 26  
D-32758 Detmold  
Germany

[www.weidmueller.com](http://www.weidmueller.com)

## Technical data

### Approvals

Approvals



ROHS	Conform
UL File Number Search	UL Website
Certificate No. (cURus)	E471884

### Downloads

Approval/Certificate/Document of Conformity	<a href="#">Certificate of Compliance</a>
Engineering Data	<a href="#">CAD data – STEP</a>
Product Change Notification	<a href="#">PCN</a> <a href="#">PCN</a>
User Documentation	<a href="#">MAN IE GUIDE DE</a> <a href="#">MAN IE GUIDE EN</a>
Catalogues	<a href="#">Catalogues in PDF-format</a>
Brochures	<a href="#">MB FREECONTACT EN</a> <a href="#">FL FIELDWIRING EN</a> <a href="#">PI PROFINET CABLING EN</a>

**RJ45G1 R12D 3.2E4YG/YG RL**

**Weidmüller Interface GmbH & Co. KG**  
 Klingenbergstraße 26  
 D-32758 Detmold  
 Germany

www.weidmueller.com

**Drawings**

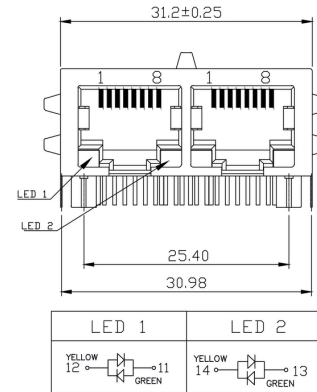

**PCB design**

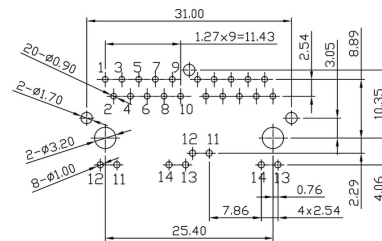
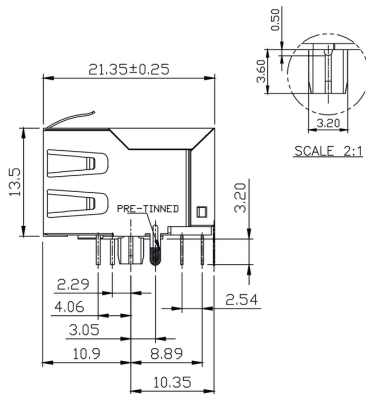

**Wiring diagram**

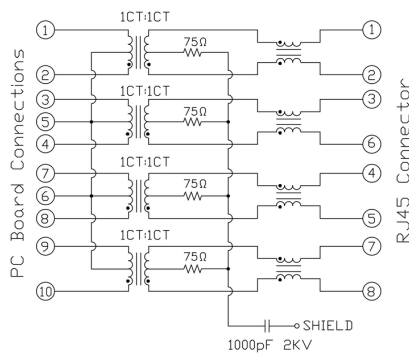

**RJ45G1 R12D 3.2E4YG/YG RL**

**Weidmüller Interface GmbH & Co. KG**  
 Klingenbergstraße 26  
 D-32758 Detmold  
 Germany

www.weidmueller.com

Drawings

Code	Value	Description
RJ45	G1	RJ45G1 R1U 3.2E4GY/GY TY
R	1	
U	3.2	
E	4	
GY/GY	TY	
<b>Packaging</b>	<b>TY</b>	Tray in box (manual assembly)
	<b>RL</b>	Tape on Reel (automated assembly)
<b>LED</b>	<b>Y/G</b>	Yellow/Green
	<b>G/Y</b>	Green/Yellow (standard)
	<b>GY/GY</b>	Green-Yellow/Green-Yellow
	<b>O/G</b>	Orange/Green
	<b>R/O</b>	Red/Orange
	<b>...</b>	... (further combinations possible)
	<b>N</b>	without LED
<b>Contact surface thickness</b>	<b>4</b>	1 = 3µ", 2 = 6µ", 3 = 15µ", 4 = 30µ", 5 = 50µ"
<b>EMI tabs (ground fingers)</b>	<b>E</b>	E = with EMI tabs
	<b>N</b>	N = without EMI tabs
<b>Solder Pin length</b>	<b>3.2</b>	3.2 mm
	<b>1.6</b>	1.6 mm
	<b>D</b>	SMD
<b>Direction, latch style</b>	<b>U</b>	Horizontal (90°, side entry), latch up
	<b>D</b>	Horizontal (90°, side entry), latch down
	<b>V</b>	Vertical (180°, top entry)
	<b>Y</b>	Diagonal (45°), latch up
<b>Number of Ports</b>	<b>1</b>	1 Port
	<b>12; 14; ...</b>	multi ports side by side, Multiport
	<b>21; 41; ...</b>	multi ports about each other, Multilevel
<b>Assembly on PCB</b>	<b>R</b>	Through Hole Reflow - THR
	<b>S</b>	Soldering process: Wave or Reflow soldering
	<b>S</b>	Surface Mount Technology - SMT
	<b>T</b>	Soldering process: Reflow soldering
	<b>T</b>	Through Hole Technology - THT
	<b>T</b>	Soldering process: Wave
<b>Performance Category</b>	<b>C5</b>	Category 5
	<b>C6</b>	Category 6
	<b>C6A</b>	Category 6A
	<b>C5e</b>	Category 5e
	<b>M</b>	10/100 Mbit
	<b>G1</b>	10/100/1000 Mbit
	<b>G10</b>	10 Gbit
	<b>U</b>	Unshielded
	<b>MP</b>	10/100 Mbit with POE
	<b>MP+</b>	10/100 Mbit with POE+

Type codes

## Recommended wave soldering profiles

**Weidmüller Interface GmbH & Co. KG**  
 Klängenbergstraße 16  
 D-32758 Detmold  
 Germany  
 Fon: +49 5231 14-0  
 Fax: +49 5231 14-292083  
 www.weidmueller.com

### Single Wave:



### Double Wave:



### Wave soldering profiles

Wired connection elements should be processed in accordance with the DIN EN 61760-1 standard. We have included two recommendations for practical wave soldering profiles, with which Weidmüller PCB terminals and connectors are qualified.

When choosing a suitable profile for your application, the following factors also need to be considered:

- PCB thickness
- Proportion of Cu in the layers
- Single/double-sided assembly
- Product range
- Heating and cooling rates

The single and double wave profiles each indicate the recommended operating range, including the maximum soldering temperature of 260°C. In practice, the maximum soldering temperature is quite often well below the above maximum profile.

## Recommended reflow soldering profile

**Weidmüller Interface GmbH & Co. KG**  
 Klingenbergstraße 16  
 D-32758 Detmold  
 Germany  
 Fon: +49 5231 14-0  
 Fax: +49 5231 14-292083  
 www.weidmueller.com



### Reflow soldering profile

The perfect soldering profile for SMT Surface Mount Technology is one the most exiting question in SMT production. But there are more than one correct answer: The diagram of temperature-on-time is related to processing features of solder paste and to maximum load of components.

We have to consider the following parameters:

- Time for pre heating
- Maximum temperature
- Time above melting point
- Time for cooling
- Maximum heating rate
- Maximum cooling rate

We recommend a typical solder profile with associated process limits. With preheating components and board are prepared smoothly for the solder phase. Heating rate is typically  $\leq +3\text{K/s}$ . In parallel the solder paste is ‚activated‘. The time above melting point of 217°C the paste gets liquid and components and boards begin to connect. The maximum temperature of 245°C to 254°C should stay between 10 and 40 seconds. In the cooling phase at  $\geq -6\text{K/s}$  solder is cured. Board and components cool down while avoiding cold cracks.