

REVISION W

NOTES:

1. $\text{\textcircled{C}}$ REPRESENTS A CRITICAL DIMENSION.
2. SHEAR TAILS TO DIMENSION SHOWN.
3. MAXIMUM BURR: .003[0.08].
4. MAXIMUM CUT FLASH: .015 [0.38].
5. NO FLASH ALLOWED IN OR AROUND SURFACE MOUNT TAIL AREA.
6. MINIMUM PUSHOUT FORCE: .5 LB.
7. MINIMUM ENDWALL THICKNESS: .008 [0.20].

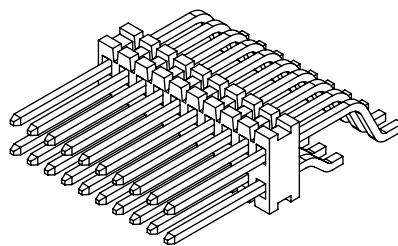

DO NOT SCALE FROM THIS PRINT

FTE-1XX-XX-X-DH-X-XX

No OF POSITIONS
-05 THRU -50
(PER ROW)

LEAD STYLE
-01: .075 POST
-02: .175 POST
-03: .120 POST

OPTION 2
-TR: TAPE & REEL PACKAGING
(SEE FIG 3, SHEET 2)

OPTION 1
-K: POLYIMIDE FILM PAD
(USE K-500-300,
SEE FIG 4, SHEET 2)

ROW SPECIFICATION
-DH: DOUBLE HORIZONTAL
(USE FTE-90-D)

PLATING SPECIFICATION

-G: 10 μ " SELECTIVE GOLD IN CONTACT AREA,
3 μ " SELECTIVE GOLD ON TAIL.

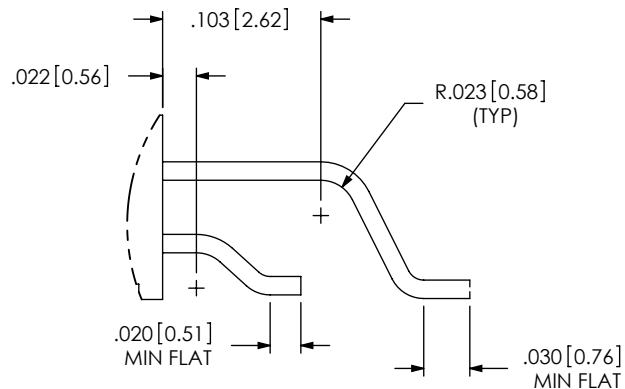
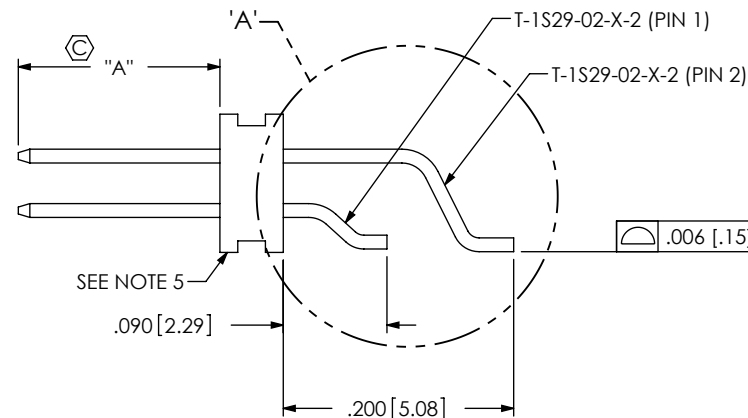
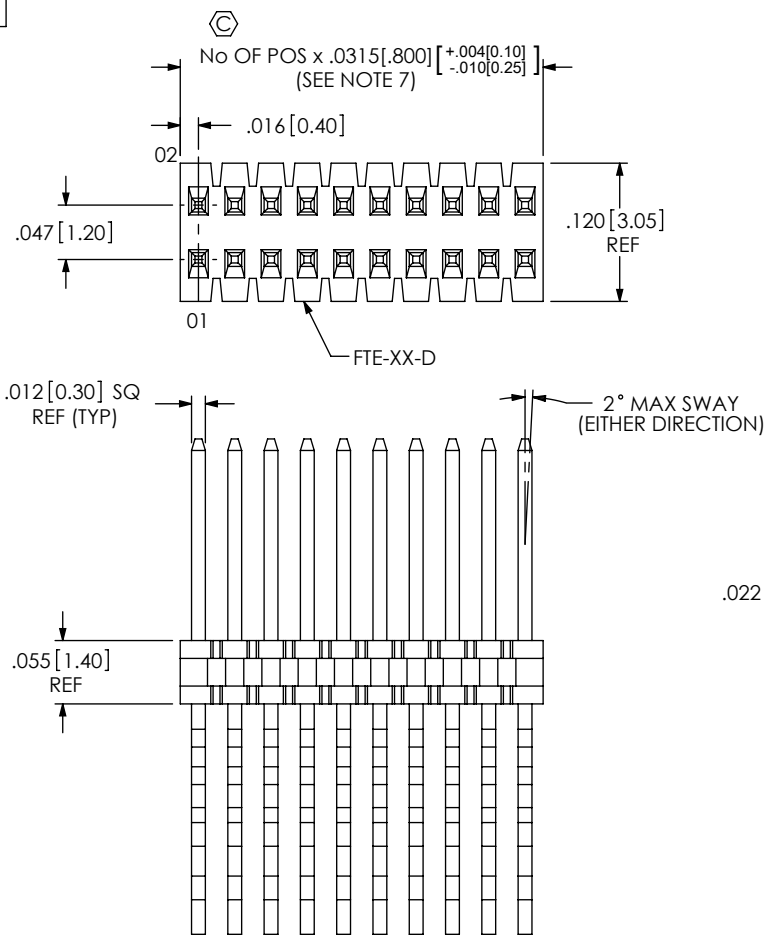

| LEAD STYLE | "A" |
|------------|-------------|
| -01 | .075[1.91] |
| -02 | .175[4.45] |
| -03 | .120 [3.05] |

FIG 1
FTE-110-02-X-DH SHOWN

DETAIL 'A'
SCALE 8:1

UNLESS OTHERWISE SPECIFIED,
DIMENSIONS ARE IN INCHES.
TOLERANCES ARE:
DECIMALS ANGLES
.XX: $\pm .01$ [0.3] 2°
.XXX: $\pm .005$ [0.13]
.XXXX: $\pm .0020$ [0.051]

PROPRIETARY NOTE
THIS DOCUMENT CONTAINS INFORMATION
CONFIDENTIAL AND PROPRIETARY TO
SAMTEC, INC. AND SHALL NOT BE REPRODUCED
OR TRANSFERRED TO OTHER DOCUMENTS OR
DISCLOSED TO OTHERS OR USED FOR ANY
PURPOSE OTHER THAN THAT WHICH IT WAS
OBTAINED WITHOUT THE EXPRESSED WRITTEN
CONSENT OF SAMTEC, INC.



520 PARK EAST BLVD., NEW ALBANY, IN 47150
PHONE: 812-944-6733 FAX: 812-948-5047
e-Mail: info@SAMTEC.com code 53322

MATERIAL: DO NOT SCALE DRAWING SHEET SCALE: 3:1
BODY: LCP, UL 94 V0, COLOR: BLACK
TERMINAL: PHOS BRONZE

DESCRIPTION: .8MM X 1.2MM C.L. TERMINAL STRIP ASSM

DWG. NO. FTE-1XX-XX-X-DH-X-XX

BY: D. PURVIS 10/13/1998 SHEET 1 OF 2

REVISION W

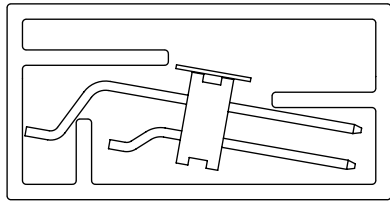

OPTIONS: -02, -03, -02-K, -03-K

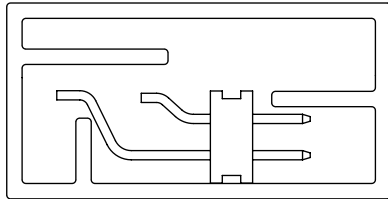

OPTIONS: -01, -01-K

FIG 2
TUBE: PT-T-24-01-92
PLUG: TP-24

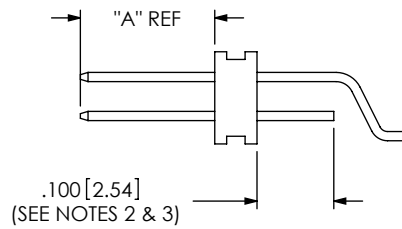

IN PROCESS 1

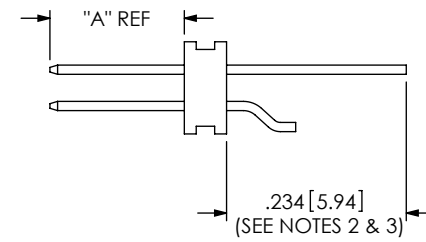

IN PROCESS 2

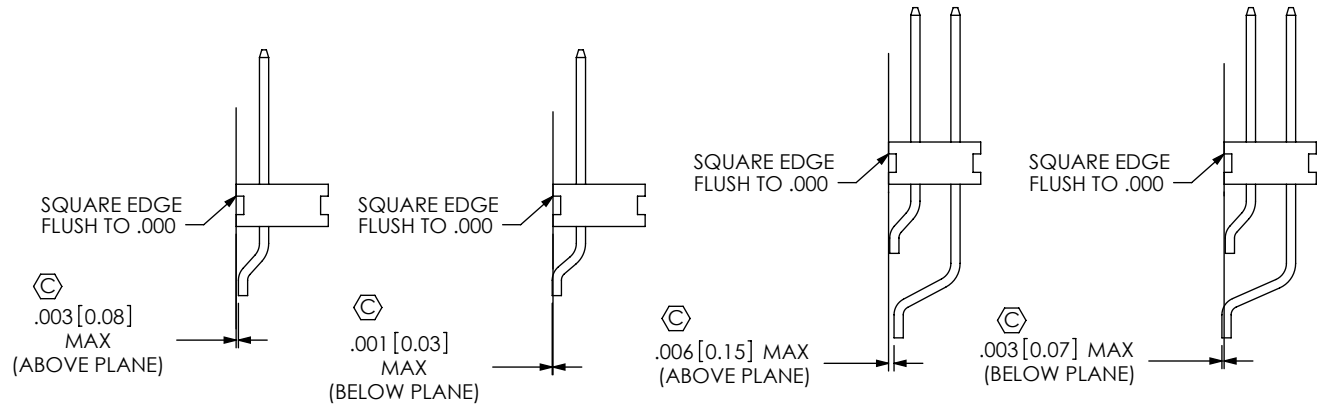

COPLANARITY VIEWS

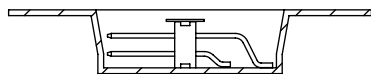
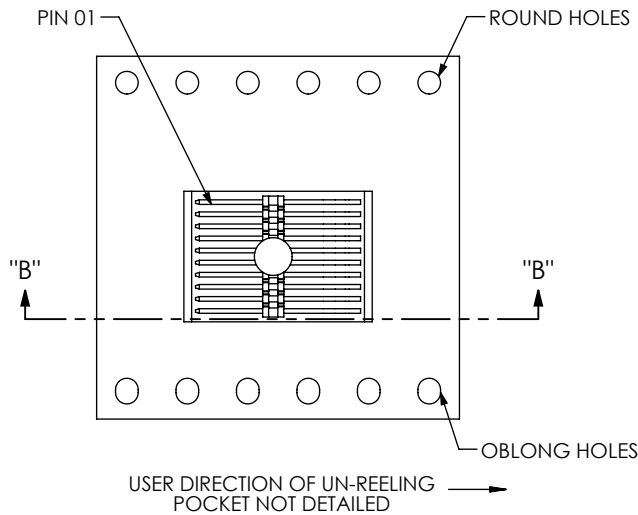

SECTION "B"- "B"
SCALE 2 : 1

FIG 3
TAPE & REEL

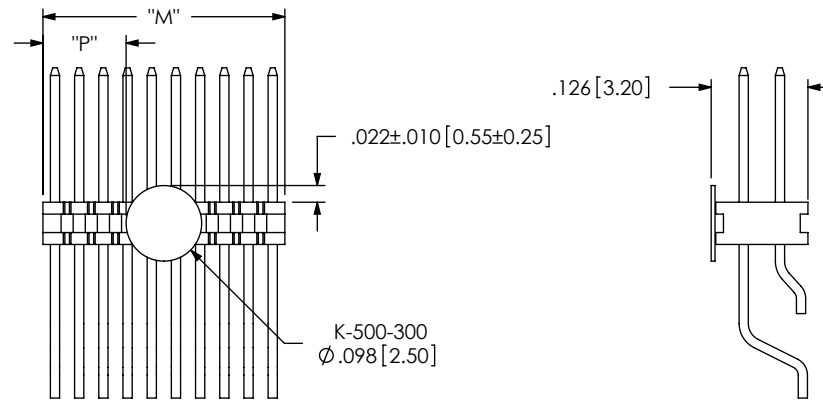

FIG 4
POLYIMIDE FILM PAD
(AVAILABLE ON -05 THRU -50 POS ONLY)

NOTE: "M" = USE MEASURED DIMENSION REF
"P" = (("M" - .098[2.50]) / 2) ±.020[0.51]

PROPRIETARY NOTE
THIS DOCUMENT CONTAINS INFORMATION
CONFIDENTIAL AND PROPRIETARY TO
SAMTEC, INC. AND SHALL NOT BE REPRODUCED
OR TRANSFERRED TO OTHER DOCUMENTS OR
DISCLOSED TO OTHERS OR USED FOR ANY
PURPOSE OTHER THAN THAT WHICH IT WAS
OBTAINED WITHOUT THE EXPRESSED WRITTEN
CONSENT OF SAMTEC, INC.

DO NOT SCALE DRAWING

SHEET SCALE: 4:1

samtec

520 PARK EAST BLVD, NEW ALBANY, IN 47150
PHONE: 812-944-6733 FAX: 812-948-5047
e-Mail info@SAMTEC.com code 55322

DESCRIPTION: .8MM X 1.2MM C.L. TERMINAL STRIP ASSM

DWG. NO. FTE-1XX-XX-X-DH-X-XX

BY: D. PURVIS 10/13/1998 SHEET 2 OF 2