

AC axial fan

sickle-shaped blades (S series), single-intake
with guard grille for full nozzle

ebm-papst Mulfingen GmbH & Co. KG

Bachmühle 2 · D-74673 Mulfingen

Phone +49 7938 81-0

Fax +49 7938 81-110

info1@de.ebmpapst.com

www.ebmpapst.com

Limited partnership · Headquarters Mulfingen

Amtsgericht (court of registration) Stuttgart · HRA 590344

General partner Elektrobau Mulfingen GmbH · Headquarters Mulfingen

Amtsgericht (court of registration) Stuttgart · HRB 590142



Nominal data

Type	S2D300-BP02-37				
Motor	M2D074-DF				
Phase		3~	3~	3~	3~
Nominal voltage	VAC	230	230	400	400
Wiring		Δ	Δ	Y	Y
Frequency	Hz	50	60	50	60
Method of obtaining data		fa	fa	fa	fa
Valid for approval/standard		CE	CE	CE	CE
Speed (rpm)	min ⁻¹	2580	2750	2580	2750
Power consumption	W	210	300	210	300
Current draw	A	0.62	0.84	0.36	0.48
Max. back pressure	Pa	200	125	200	125
Max. back pressure	inH ₂ O	0.8	0.5	0.8	0.5
Min. ambient temperature	°C	-25	-25	-25	-25
Max. ambient temperature	°C	75	40	75	40
Starting current	A	2.0	1.9	1.16	1.1

ml = Max. load · me = Max. efficiency · fa = Free air · cs = Customer specification · ce = Customer equipment
Subject to change

Data according to ErP Directive

	Actual	Req. 2015				
01 Overall efficiency η_{es}	%	29.9	29.9	09 Power consumption P_e	kW	0.25
02 Measurement category	A			09 Air flow q_v	m ³ /h	2210
03 Efficiency category	Static			09 Pressure increase p_{fs}	Pa	125
04 Efficiency grade N	40	40		10 Speed (rpm) n	min ⁻¹	2455
05 Variable speed drive	No			11 Specific ratio*		1.00

Data obtained at optimum efficiency level.
The ErP data is determined using a motor-impeller combination in a standardized measurement setup.

* Specific ratio = $1 + p_{fs} / 100\,000\text{ Pa}$

LU-62732



AC axial fan

sickle-shaped blades (S series), single-intake
with guard grille for full nozzle

Technical description

Weight	3.8 kg
Fan size	300 mm
Rotor surface	Painted black
Blade material	Sheet steel, painted black
Guard grille material	Steel, coated with black plastic (RAL 9005)
Number of blades	5
Airflow direction	"V"
Direction of rotation	Counterclockwise, viewed toward rotor
Degree of protection	IP44; installation- and position-dependent as per EN 60034-5
Insulation class	"F"
Moisture (F) / Environmental (H) protection class	F2-2
Max. permitted ambient temp. for motor (transport/storage)	+ 80 °C
Min. permitted ambient temp. for motor (transport/storage)	- 40 °C
Installation position	Shaft horizontal or rotor on bottom; rotor on top on request
Condensation drainage holes	On rotor side
Mode	S1
Motor bearing	Ball bearing
Touch current according to IEC 60990 (measuring circuit Fig. 4, TN system)	< 0.75 mA
Motor protection	Thermal overload protector (TOP) with basic insulation
With cable	Variable
Protection class	I (with customer connection of protective earth)
Approval	EAC

AC axial fan

sickle-shaped blades (S series), single-intake
with guard grille for full nozzle

Product drawing

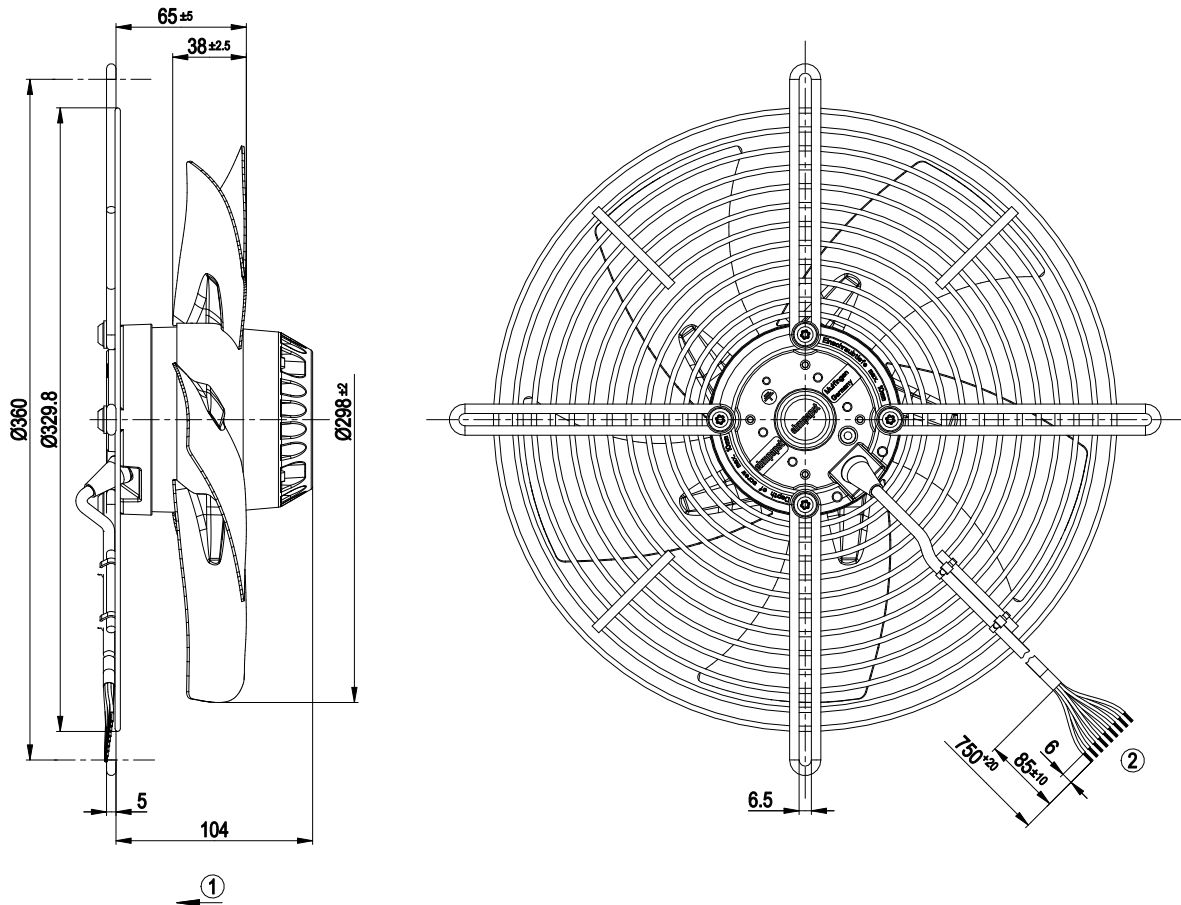

- | | |
|---|---|
| 1 | Direction of air flow "V" |
| 2 | Cable halogen-silicone-free 9G 0.5 mm ² , 9x crimped splices |



AC axial fan

sickle-shaped blades (S series), single-intake
with guard grille for full nozzle

Connection diagram

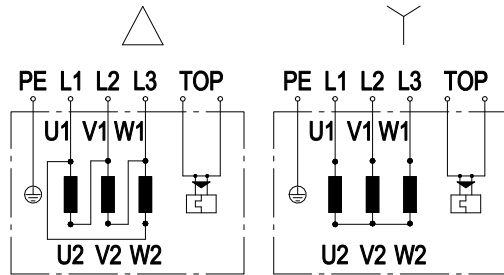

Note: Change of rotation direction by reversing two phases

Δ	Delta connection	Y	Star connection	L1	black
L2	blue	L3	brown	U1	black
V1	blue	W1	brown	U2	green
V2	white	W2	yellow	TOP	2x gray
PE	green/yellow				



AC axial fan

sickle-shaped blades (S series), single-intake
with guard grille for full nozzle

Curves: Air performance 50 Hz

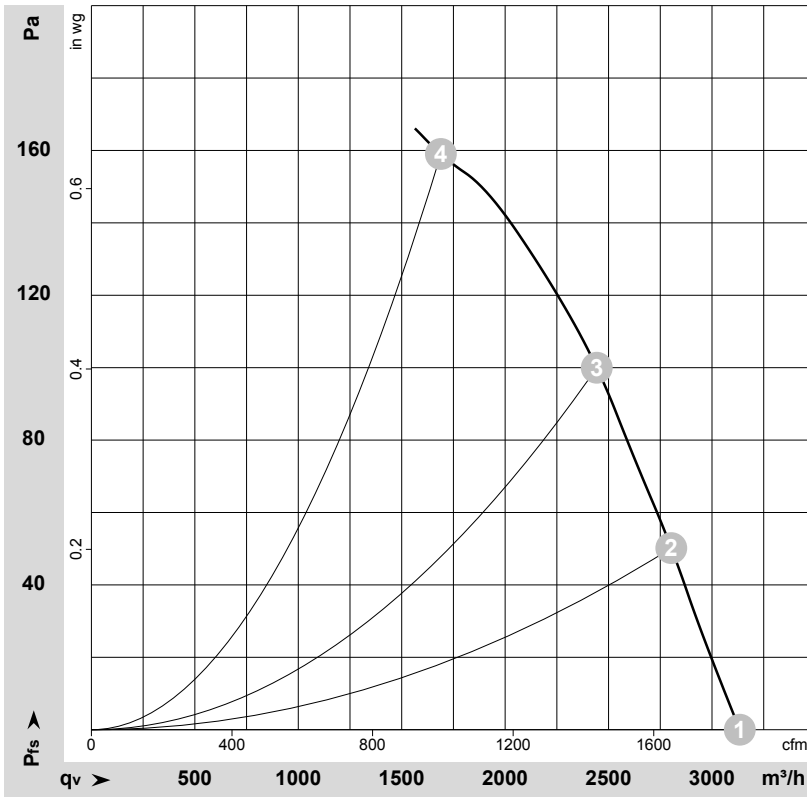

$\rho = 1.15 \text{ kg/m}^3 \pm 2 \%$

Measurement: LU-62732-1

Air performance measured according to ISO 5801 installation category A. For detailed information on the measurement setup, contact ebmpapst. Intake sound level: Sound power level according to ISO 13347 / sound pressure level measured at 1 m distance from fan axis. The values given are valid under the specified measuring conditions and may vary due to conditions of installation. For deviations from the standard configuration, the parameters have to be checked on the installed unit.

Measured values

	Wired	U	f	n	P _e	I	qv	p _{fs}	qv	p _{fs}
		V	Hz	min ⁻¹	W	A	m ³ /h	Pa	CFM	inH ₂ O
1	Y	400	50	2580	210	0.36	3135	0	1845	0.00
2	Y	400	50	2540	228	0.36	2805	50	1650	0.20
3	Y	400	50	2490	244	0.39	2445	100	1440	0.40
4	Y	400	50	2385	281	0.44	1690	160	995	0.64

Wired = Wiring · U = Power supply · f = Frequency · n = Speed (rpm) · P_e = Power consumption · I = Current draw · qv = Air flow · p_{fs} = Pressure increase



AC axial fan

sickle-shaped blades (S series), single-intake
with guard grille for full nozzle

Curves: Air performance 60 Hz

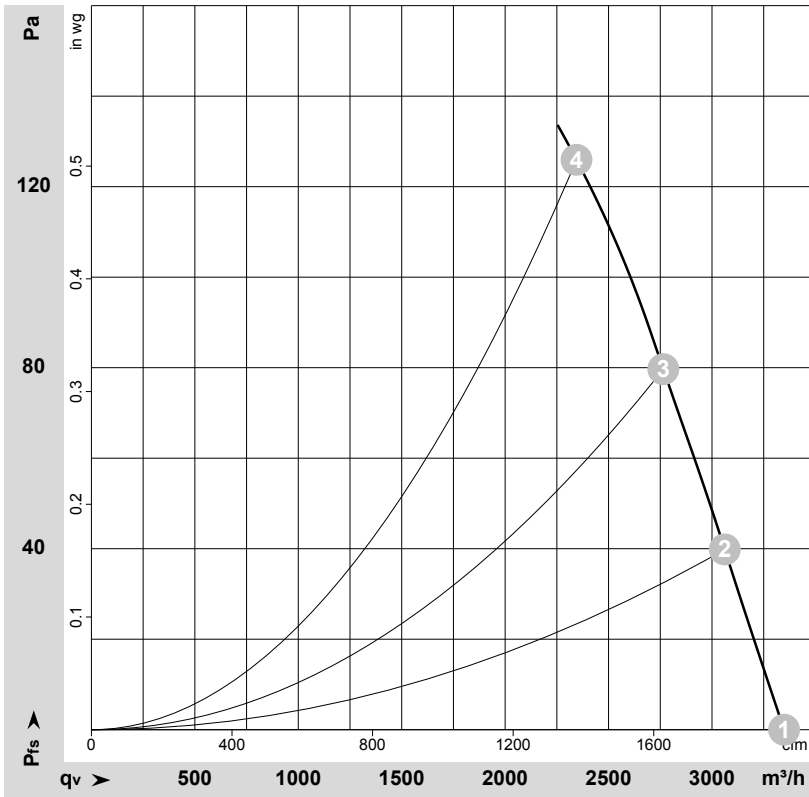

$\rho = 1.15 \text{ kg/m}^3 \pm 2 \%$

Measurement: LU-62733-1

Air performance measured according to ISO 5801 installation category A. For detailed information on the measurement setup, contact ebm-papst. Intake sound level: Sound power level according to ISO 13347 / sound pressure level measured at 1 m distance from fan axis. The values given are valid under the specified measuring conditions and may vary due to conditions of installation. For deviations from the standard configuration, the parameters have to be checked on the installed unit.

Measured values

	U	f	n	P _e	I	qv	p _{fs}	qv	p _{fs}
	V	Hz	min ⁻¹	W	A	m ³ /h	Pa	CFM	inH ₂ O
1	400	60	2750	300	0.48	3350	0	1970	0.00
2	400	60	2685	316	0.48	3060	40	1800	0.16
3	400	60	2625	331	0.50	2765	80	1625	0.32
4	400	60	2540	349	0.53	2345	125	1380	0.50

U = Power supply · f = Frequency · n = Speed (rpm) · P_e = Power consumption · I = Current draw · qv = Air flow · p_{fs} = Pressure increase

