

PCB Relay G5LA

A Cubic, Single-pole 10A Power Relay

- Economical cube relay with universal terminal footprint
- Conforms to VDE0435, CQC
- UL recognized/ CSA certified.
- High switching power: 10A @ 250VAC
- Withstands impulse of up to 4,500V
- Coil power consumption: 360mW
- UL Class F coil insulation type also available
- Tracking resistance: CTI>250
- RoHS Compliant

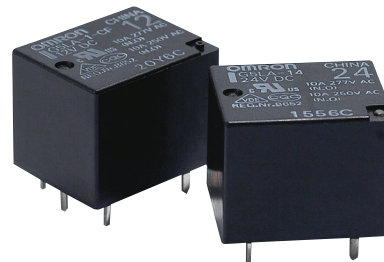

Ordering Information

Type	Contact form	Enclosure ratings	Model
Standard	SPST-NO (Class A)	Flux protection	G5LA-1A
		Sealed	G5LA-1A4
	SPST-NO (Class F)	Flux protection	G5LA-1A-CF
		Sealed	G5LA-1A4-CF
	SPDT (Class A)	Flux protection	G5LA-1
		Sealed	G5LA-14
	SPDT (Class F)	Flux protection	G5LA-1-CF
		Sealed	G5LA-14-CF
High-capacity	SPDT (Class A)	Flux protection	G5LA-1-E
		Sealed	G5LA-14-E
	SPDT (Class F)	Flux protection	G5LA-1-E-CF
		Sealed	G5LA-14-E-CF

Note: When ordering, add the rated coil voltage to the model number.
Example: G5LA-1 DC12

Rated coil voltage

Model Number Legend

G5LA- - - DC

1 2 3 4 5 6

1. Number of Poles

1: 1 pole

2. Contact Form

None: SPDT

A: SPST-NO

3. Enclosure Ratings

None: flux protection

4: fully sealed

4. Type

None: Standard

E: High Capacity (SPDT only)

5. Insulation Class

None: Class A

CF: Class F

6. Rated Coil Voltage

5, 9, 12, 24, or 48

Specifications

■ Coil Ratings

Rated Voltage (VDC)	Rated current (mA)	Coil resistance (Ω)	Must operate voltage	Must release voltage	Rated power consumption (W)	Max voltage
5	72	69.4	75% max.	10% min.	Approx. 0.36	130% of rated voltage at 85°C 170% of rated voltage at 23°C
9	40	225				
12	30	400				
24	15	1600				
48	10	4800			Approx. 0.48	

Note: 1. The rated current and coil resistance are measured at a coil temperature of 23°C with tolerances of $\pm 10\%$.
2. Please avoid ultrasonic cleaning this relay.

■ Contact Ratings

Rated load (resistive)	SPST-NO	10 A @ 250 VAC (NO)	10 A @ 24 VDC (NO)
	SPDT	5 A @ 125 VAC (NO/NC)	5 A @ 24 VDC (NO/NC)
	High-capacity	5 A @ 250 VAC (NO/NC)	5 A @ 24 VDC (NO/NC)
Rated carry current	10 A (SPST-NO)	10 A (High-capacity)	5 A (SPDT)
Max. switching voltage	250 VAC	24 VDC	
Max. switching current	10 A	SPST-NO	
	5 A	SPDT, High-capacity	
Max. switching capacity	2500 VA, 240 W (NO)	625 VA, 120 W (NC)	1250 VA, 120 W (NO/NC High-capacity)
Min. permissible load	100 mA at DC5V (P level: $\lambda_{60} = 0.1 \times 10^{-6}$ / ops)		
Contact Material	AgSnO ₂		

Note: SPDT type can switch up to 10 A @ 250 VAC/24 VDC Resistive Load on NO contact if there is no load on the NC contact.

■ Characteristics

Contact resistance	100 m Ω max.
Operate time	10 ms max.
Release time	5 ms max.
Max. operating frequency	Mechanical: 18,000 operations/hr Electrical: 1,800 operations/hr (under rated load)
Insulation resistance	1,000 M Ω min. (at 500 VDC)
Dielectric strength	2,000 VAC, 50/60 Hz for 1 minute between coil and contacts 750 VAC, 50/60 Hz for 1 minute between contacts of same polarity
Vibration resistance	Destruction: 10 to 55 Hz, 1.5-mm double amplitude Malfunction: 10 to 55 Hz, 1.5-mm double amplitude
Shock resistance	Destruction: 1,000 m/s ² (approx. 100G) Malfunction: 100 m/s ² (approx. 10G)
Life expectancy	Mechanical: 10,000,000 operations min. (at 18,000 operations/hr under no load) Electrical: 100,000 operations average. (at 1,800 operations/hr under rated load)
Ambient temperature	Operating:- 40°C to 85°C (with no icing or condensation) Storage: -40°C to 85°C (with no icing or condensation)
Ambient humidity	Operating: 35% to 85% Storage: 35% to 85%
Weight	Approx. 7.5g

Note: 1. Data shown are of initial value.
2. All G5LA Class A rated relays are factory guaranteed to maximum Operating Temperature of 85°C.
UL rated maximum temperature is pending approval for Class B rating.

■ Approved Standards

UL Recognized (File No. E41643) & CSA Certified (File No. LR31928) - - Ambient Temp. = 40°C

Model	Coil rating	Contact rating
G5LA	5 to 48 VDC	NO: 10 A, 277 VAC, general use, 100,000 cycles 10 A, 30 VDC, resistive, 50,000 cycles 1/2 HP, 125-250VAC, 1,000 cycles 10 A, 277 VAC, general use, 85°C 50,000 cycles (-CF type only) 200 W Tungsten, 125 VAC, 100,000 cycles NC: 10 A, 125 VAC, resistive 10 A, 277 VAC, general use, 100,000 cycles (-E type only) 10A, 24 VDC, resistive, 100,000 cycles (-E type only)

VDE0435 (EN61810-1)

Model	Coil rating	Contact rating
G5LA	5,9,12,24,48 VDC	NO: 10 A, 250 VAC, resistive, 85°C - flux protection: 50,000 cycles - fully sealed: 10,000 cycles 12 A, 125 VAC, resistive, 85°C, 10,000 cycles CO: 5 A, 250 VAC, resistive, 85°C - flux protection: 50,000 cycles - fully sealed: 10,000 cycles

CQC

Model	Coil rating	Contact rating
G5LA	5,9,12,24,48 VDC	NO: 10 A, 250 VAC, resistive, 10,000 cycles 12 A, 120 VAC, resistive, 10,000 cycles

Dimensions

Note: All units are in millimeters unless otherwise indicated.

■ SPDT Models

Terminal Arrangement/Internal Connections (Bottom View)

Mounting Holes (Bottom View)
Tolerance: ± 0.1 mm
Unless specified

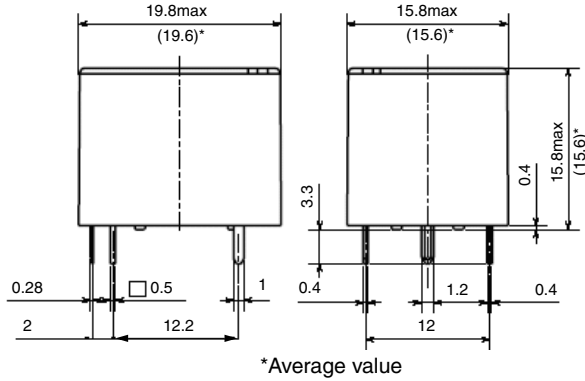

SPDT

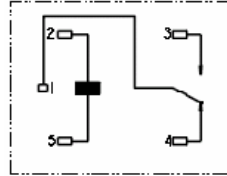

SPDT

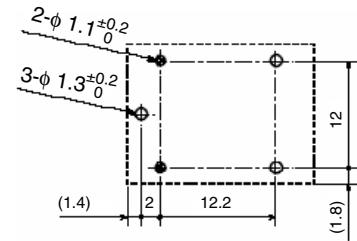

■ SPST-NO Models

Terminal Arrangement/Internal Connections (Bottom View)

Mounting Holes (Bottom View)
Tolerance: ± 0.1 mm
Unless specified

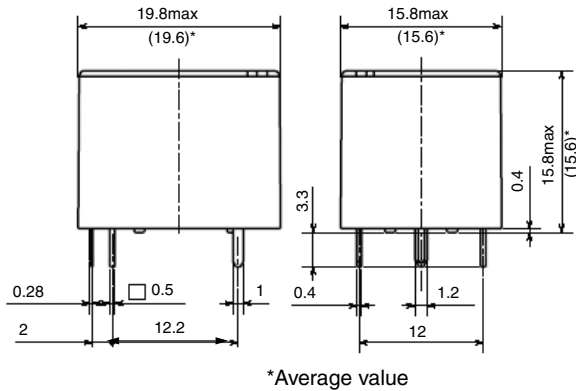

SPST-NO

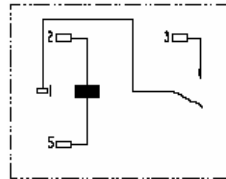

SPST-NO

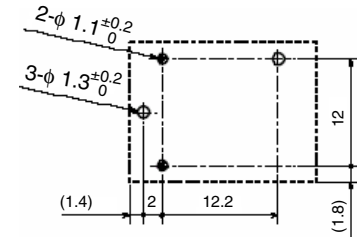

Engineering Data

Maximum switching capacity (NO)

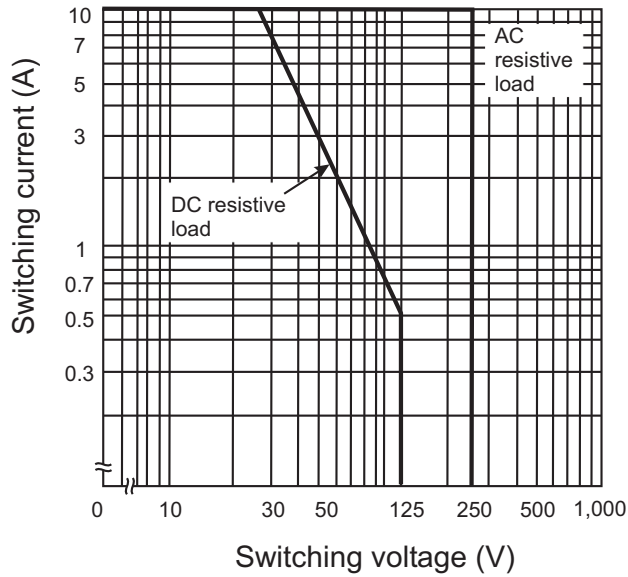

Electrical service life NO (Average value)

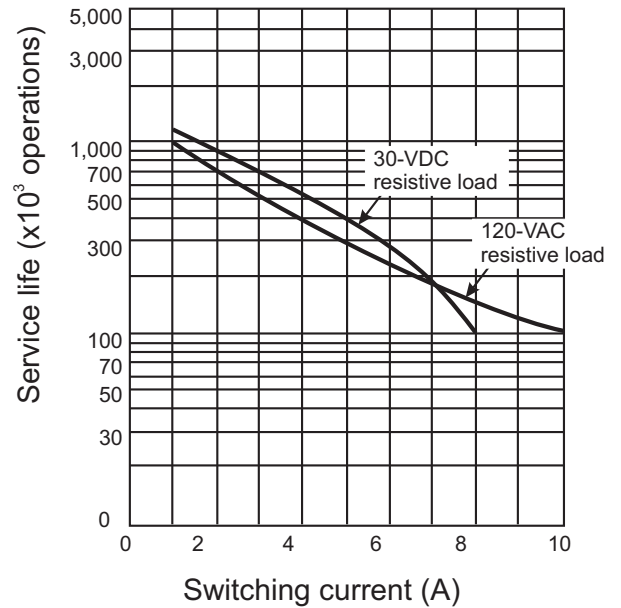

Note: The 120 VAC resistive load service life curve also applies for 250 VAC resistive load.

Ambient Temperature vs. Maximum Coil Voltage

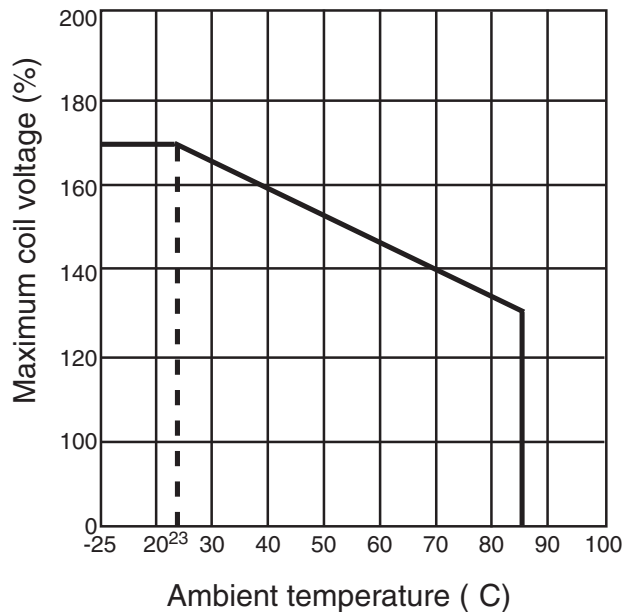

Note: The maximum coil voltage refers to the maximum value in a varying range of operating power voltage not a continuous voltage.

All sales are subject to Omron Electronic Components LLC standard terms and conditions of sale, which can be found at http://www.components.omron.com/components/web/webfiles.nsf/sales_terms.html

ALL DIMENSIONS SHOWN ARE IN MILLIMETERS.

To convert millimeters into inches, multiply by 0.03937. To convert grams into ounces, multiply by 0.03527.

OMRON[®]

**OMRON ELECTRONIC
COMPONENTS LLC**

55 E. Commerce Drive, Suite B
Schaumburg, IL 60173

847-882-2288

OMRON ON-LINE

Global - <http://www.omron.com>

USA - <http://www.components.omron.com>

Cat. No. X301-E-1c

12/14 (09/11)

Specifications subject to change without notice

Printed in USA