

SD

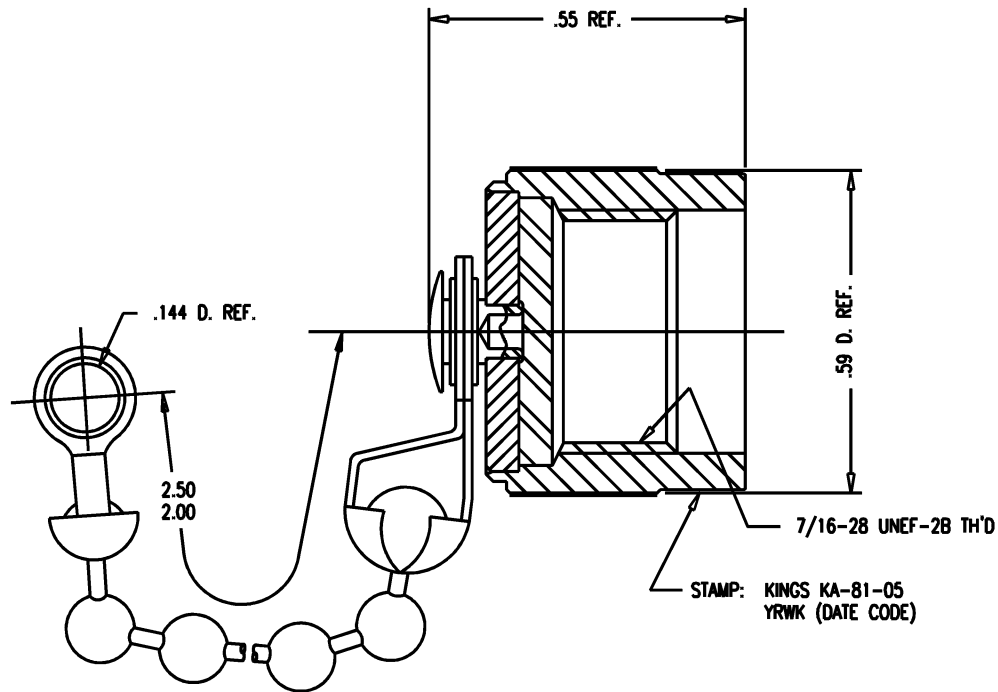

NOTES:

1. APPLY SMALL AMOUNT OF ADHESIVE GENERAL ELECTRIC RTV-112 OR EQUAL TO SURFACE AS SHOWN.
2. MARK PACKAGE: KINGS KA-81-05 YRWK (DATE CODE)
3. CHAIN MUST ROTATE FREELY.
4. MATERIALS:
 PAD: SILICONE RUBBER, A-A 59588
 BEAD CHAIN: STAINLESS STEEL, 303
 ALL OTHER METAL PARTS: BRASS, ASTM-B16
5. FINISHES:
 COUPLINGS: NICKEL PLATE, SAE-AMS-QQ-N-290
 BEAD CHAIN: PASSIVATE, SAE-AMS-QQ-P-35
 ALL OTHER METAL PARTS: SILVER PLATE, ASTM-B700

REVISIONS	
ISSUE	CHANGES
0	ER 6549 07/12/68
1	CN 7757 A RHW 07/08/69
2	CN 12312 A JL 06/04/73
3	CN 37796 E REDRAWN TML 03/25/99

4	CN 39383 E DRK 01/04/06
---	----------------------------

SCALE 4:1

APPROX SURFACE AREA

USED ON

REF: MCDONNELL DOUGLAS, STSM1418-002

CAP & CHAIN, TNC

DRAWN RFO	DATE 07/12/68
-----------	---------------

DESIGN	DATE
--------	------

APPR. EGR	DATE 07/12/68
-----------	---------------

KINGS
ELECTRONICS CO., INC.
ROCK HILL, SOUTH CAROLINA 29730

SD

KA-81-05