

Solid State Relays Industrial, 1-Phase ZS/(IO), Standard Range Types RA 24.. .. 06/RA 44.. .. 08/RA 48.. .. 12

CARLO GAVAZZI



- AC Solid State Relay
- Zero switching (RA) or instant-on switching (RB)
- Direct copper bonding technology
- Rated operational current: 10, 25, 50 and 90 AACrms
- Non-repetitive voltage: Up to 1200 V_p
- Rated operational voltage: Up to 480 VACrms
- 3 input ranges: 3 to 32 VDC, 10 to 90 VAC/DC and 90 to 280 VAC/DC
- Insulation: OPTO (input-output) 4000 VACrms

Product Description

The zero switching relay with antiparallel thyristor output is the most widely used industrial SSR due to its multiple application possibilities. The relay can be used for resistive, inductive and capacitive loads. The zero switching relay switches ON when the sine curve just crosses zero and switches OFF when the current crosses zero.

ive, inductive and capacitive loads. The zero switching relay switches ON when the sine curve just crosses zero and switches OFF when the current crosses zero.

Ordering Key

RA 24 90 -D 06

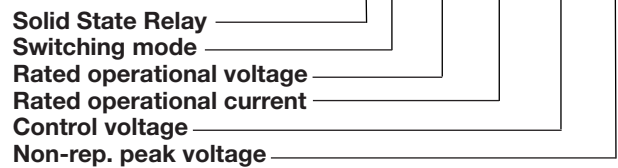

Type Selection

Switching mode	Rated operational voltage	Rated operational current	Control voltage	Non-rep. voltage
A: Zero switching Optional: B: Instant-on switching	24: 230 VACrms 44: 400 VACrms 48: 480 VACrms	10: 10 AACrms 25: 25 AACrms 50: 50 AACrms 90: 90 AACrms	-D: 3 to 32 VDC LA: 10 to 90 VAC/DC HA: 90 to 280 VAC/DC	06: 650 V _p 08: 850 V _p 12: 1200 V _p

Selection Guide

Rated operational voltage	Non-rep. voltage	Control voltage	Rated operational current			
			10 AACrms	25 AACrms	50 AACrms	90 AACrms
230 VACrms	650 V _p	3 to 32 VDC	RA 2410 -D 06	RA 2425 -D 06	RA 2450 -D 06	RA 2490 -D 06
		10 to 90 VAC/DC	RA 2410 LA 06	RA 2425 LA 06	RA 2450 LA 06	RA 2490 LA 06
		90 to 280 VAC/DC	RA 2410 HA 06	RA 2425 HA 06	RA 2450 HA 06	RA 2490 HA 06
400 VACrms	850 V _p	3 to 32 VDC	RA 4410 -D 08	RA 4425 -D 08	RA 4450 -D 08	RA 4490 -D 08
		10 to 90 VAC/DC	RA 4410 LA 08	RA 4425 LA 08	RA 4450 LA 08	RA 4490 LA 08
		90 to 280 VAC/DC	RA 4410 HA 08	RA 4425 HA 08	RA 4450 HA 08	RA 4490 HA 08
480 VACrms	1200 V _p	3 to 32 VDC	RA 4810 -D 12	RA 4825 -D 12	RA 4850 -D 12	RA 4890 -D 12
		10 to 90 VAC/DC	RA 4810 LA 12	RA 4825 LA 12	RA 4850 LA 12	RA 4890 LA 12
		90 to 280 VAC/DC	RA 4810 HA 12	RA 4825 HA 12	RA 4850 HA 12	RA 4890 HA 12



General Specifications

	RA 24.. .. 06	RA 44.. .. 08	RA 48.. .. 12
Operational voltage range	24 to 280 VACrms	42 to 480 VACrms	42 to 530 VACrms
Non-rep. peak voltage	$\geq 650 V_p$	$\geq 850 V_p$	$\geq 1200 V_p$
Zero voltage turn-on	$\leq 20 V$	$\leq 40 V$	$\leq 40 V$
Operational frequency range	45 to 65 Hz	45 to 65 Hz	45 to 65 Hz
Power factor	$\geq 0.5 @ 230 VACrms$	$\geq 0.5 @ 400 VACrms$	$\geq 0.5 @ 480 VACrms$
Approvals	UL, CSA (10, 25, 50 A) CSA (90 A)	UL, CSA (10, 25, 50 A) CSA (90 A)	UL, CSA (10, 25, 50 A) CSA (90 A)
CE-marking	Yes	Yes	Yes

Input Specifications

	RA -D ..	RA LA ..	RA HA ..
Control voltage range	3 to 32 VDC	10 to 90 VAC/DC	90 to 280 VAC/DC
Pick-up voltage	$\leq 3 VDC$	$\leq 10 VAC/DC$	$\leq 90 VAC/DC$
Drop-out voltage	$\geq 1 VDC$	$\geq 1 VAC/DC$	$\geq 10 VAC/DC$
Reverse voltage	$\leq 32 VDC$		
Input impedance	1.5 k Ω	5.4 k Ω	44 k Ω
Response time pick-up			
RA	$\leq 1/2$ cycle	≤ 1 cycle	≤ 1 cycle
RB	≤ 1 ms	≤ 1 ms	≤ 1 ms
Control pulse width	≥ 0.5 ms	≥ 0.5 ms	≥ 0.5 ms
Response time drop-out	$\leq 1/2$ cycle	$\leq 1/2$ cycle	$\leq 1/2$ cycle

Output Specifications

	RA ..10	RA ..25	RA ..50	RA ..90
Rated operational current AC 1	16 Arms	25 Arms	50 Arms	90 Arms
AC 3	3 Arms	5 Arms	15 Arms	20 Arms
Minimum operational current	20 mArms	20 mArms	20 mArms	20 mArms
Rep. overload current t=1 s	≤ 35 Arms	≤ 55 Arms	≤ 125 Arms	≤ 150 Arms
Non-rep. surge current t=20 ms	160 A _p	250 A _p	600 A _p	1000 A _p
Off-state leakage current @ rated voltage and frequency	≤ 2.5 mArms	≤ 3 mArms	≤ 3 mArms	≤ 3 mArms
I ² t for fusing t=1-10 ms	$\leq 130 A^2s$	$\leq 310 A^2s$	$\leq 1800 A^2s$	$\leq 5000 A^2s$
Critical di/dt	$\geq 100 A/\mu s$	$\geq 100 A/\mu s$	$\geq 100 A/\mu s$	$\geq 100 A/\mu s$
On-state voltage drop @ rated current	$\leq 1.6 Vrms$	$\leq 1.6 Vrms$	$\leq 1.6 Vrms$	$\leq 1.6 Vrms$
Critical dV/dt commutating	$\geq 500 V/\mu s$	$\geq 500 V/\mu s$	$\geq 500 V/\mu s$	$\geq 500 V/\mu s$
Critical dV/dt off-state	$\geq 500 V/\mu s$	$\geq 500 V/\mu s$	$\geq 500 V/\mu s$	$\geq 500 V/\mu s$

Thermal Specifications

	RA ..10	RA ..25	RA ..50	RA ..90
Operating temperature	-20° to +70°C (-4° to +158°F)	-20° to +70°C (-4° to +158°F)	-20° to +70°C (-4° to +158°F)	-20° to +70°C (-4° to +158°F)
Storage temperature	-40° to +100°C (-40 to +212°F)	-40° to +100°C (-40 to +212°F)	-40° to +100°C (-40 to +212°F)	-40° to +100°C (-40 to +212°F)
Junction temperature	$\leq 125^\circ C (\leq 257^\circ F)$	$\leq 125^\circ C (\leq 257^\circ F)$	$\leq 125^\circ C (\leq 257^\circ F)$	$\leq 125^\circ C (\leq 257^\circ F)$
R _{th} junction to case	$\leq 2.0 K/W$	$\leq 1.25 K/W$	$\leq 0.65 K/W$	$\leq 0.3 K/W$
R _{th} junction to ambient	$\leq 12.5 K/W$	$\leq 12 K/W$	$\leq 12 K/W$	$\leq 12 K/W$

Insulation

Rated insulation voltage Input to output	≥ 4000 VACrms
Rated insulation voltage Output to case	≥ 4000 VACrms
Insulation resistance Input to output	≥ 10 ¹⁰ Ω
Insulation resistance Output to case	≥ 10 ¹⁰ Ω
Insulation capacitance Input to output	≤ 8 pF
Insulation capacitance Output to case	≤ 100 pF

Accessories

Protection cover
Heatsinks
DIN rail adapter
Varistors
Fuses

For further information refer to "General Accessories".

Wiring Diagram

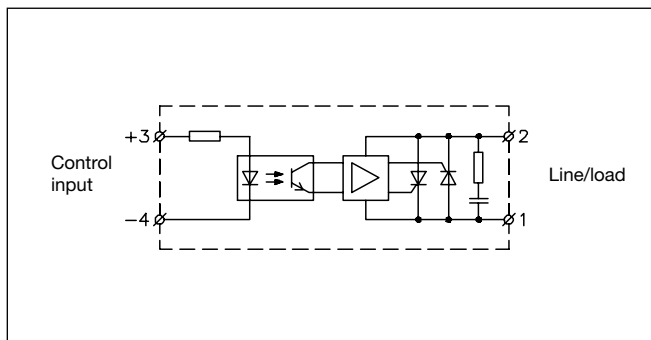

Functional Diagram

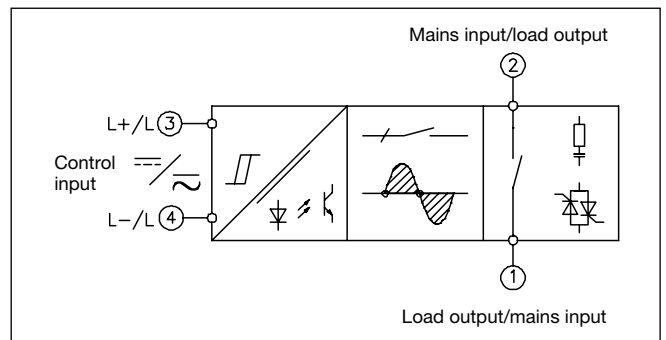

Dimensions

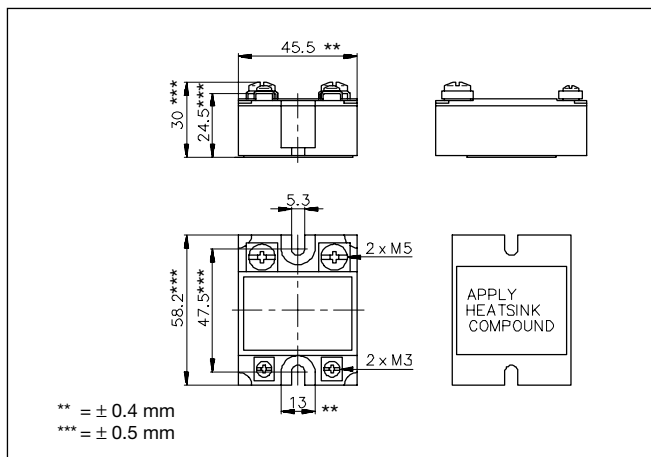

Housing Specifications

Weight	Approx. 110 g
Housing material	Noryl GFN 1, black
Base plate	10, 25, 50 A 90 A
Potting compound	Polyurethane
Relay	
Mounting screws	M5
Mounting torque	≤ 1.5 Nm
Control terminal	
Mounting screws	M3 x 6
Mounting torque	≤ 0.5 Nm
Power terminal	
Mounting screws	M5 x 6
Mounting torque	≤ 2.4 Nm



Heatsink Dimensions (load current versus ambient temperature)

RA ..10

Load current [A]	Thermal resistance [K/W]						Power dissipation [W]
	20	30	40	50	60	70	
16	2.7	2.2	1.8	1.3	0.87	0.41	22
15	3.1	2.6	2.1	1.7	1.2	0.65	20
14	3.7	3.1	2.6	2	1.5	0.92	18
13	4.3	3.7	3.1	2.5	1.9	1.2	16
12	5	4.3	3.7	3	2.3	1.6	15
11	5.9	5.1	4.4	3.6	2.8	2.1	13
10	6.9	6	5.2	4.3	3.5	2.6	12
9	7.9	6.9	5.9	4.9	4	3	10
7	10.8	9.5	8.1	6.8	5.4	4.1	7
5	-	14.2	12.2	10.2	8.1	6.1	5
3	-	-	-	-	14.6	10.9	3
1	-	-	-	-	-	-	1

Ambient temp. [°C]

RA ..25

Load current [A]	Thermal resistance [K/W]						Power dissipation [W]
	20	30	40	50	60	70	
25	2	1.7	1.4	1	0.71	0.40	32
22.5	2.5	2.1	1.8	1.4	1	0.66	27
20	3.1	2.7	2.3	1.9	1.4	1	23
17.5	4	3.5	3	2.5	2	1.4	20
15	4.9	4.3	3.7	3.1	2.5	1.9	16
12.5	6.2	5.4	4.6	3.9	3.1	2.3	13
10	8.1	7.1	6.1	5.1	4	3	10
7.5	11.3	9.9	8.5	7.1	5.6	4.2	7
5	-	15.6	13.3	11.1	8.9	6.7	5
2.5	-	-	-	-	18.7	14	2

Ambient temp. [°C]

RA ..50

Load current [A]	Thermal resistance [K/W]						Power dissipation [W]
	20	30	40	50	60	70	
50	0.92	0.76	0.60	0.45	0.29	-	63
45	1.2	0.99	0.80	0.62	0.44	0.26	55
40	1.5	1.3	1.1	0.85	0.63	0.42	47
35	1.9	1.6	1.4	1.1	0.89	0.63	40
30	2.4	2.1	1.8	1.5	1.2	0.91	33
25	3	2.7	2.3	1.9	1.5	1.1	26
20	3.9	3.5	3	2.5	2	1.5	20
15	5.5	4.8	4.1	3.4	2.7	2.1	15
10	8.6	7.5	6.4	5.4	4.3	3.2	9
5	17.9	15.6	13.4	11.2	8.9	6.7	4

Ambient temp. [°C]

RA ..90

Load current [A]	Thermal resistance [K/W]						Power dissipation [W]
	20	30	40	50	60	70	
90	0.63	0.53	0.42	0.32	-	-	97
80	0.81	0.69	0.57	0.45	0.33	-	84
70	1	0.89	0.75	0.61	0.47	0.33	71
60	1.3	1.2	1	0.83	0.66	0.49	59
50	1.7	1.5	1.3	1.1	0.85	0.64	47
40	2.2	1.9	1.7	1.4	1.1	0.83	36
30	3.1	2.7	2.3	1.9	1.5	1.2	26
20	4.8	4.2	3.6	3	2.4	1.8	17
10	10	8.8	7.5	6.3	5	3.8	8

Ambient temp. [°C]

Heatsink Selection

Carlo Gavazzi Heatsink (see Accessories)	Thermal resistance
No heatsink required	$R_{th\ s-a} > 12.5$ K/W
RHS 100 Assy	3.0 K/W
RHS 301 Assy	0.8 K/W
RHS 301 F Assy	0.25 K/W
Consult your distributor	< 0.25 K/W

Compare the value found in the current versus temperature chart with the standard heatsink values and select the heatsink with the next lower value.



Applications

This relay is designed for use in applications in which it is exposed to high surge conditions. Care must be taken to ensure proper heatsinking when the relay is to be used at high sustained currents. Adequate electrical connection between relay terminals and cable must be ensured.

Thermal characteristics

The thermal design of Solid State Relays is very impor-

tant. It is essential that the user makes sure that cooling is adequate and that the maximum junction temperature of the relay is not exceeded.

If the heatsink is placed in a small closed room, control panel or the like, the power dissipation can cause the ambient temperature to rise. The heatsink is to be calculated on the basis of the ambient temperature and the increase in temperature.

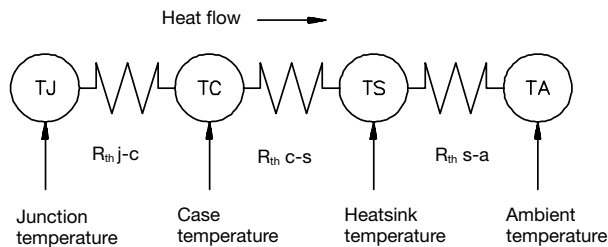

Thermal resistance:
R_{th j-c} = junction to case

R_{th c-s} = case to heatsink
R_{th s-a} = heatsink to ambient

Direct bonding

In the design of the output power semiconductor direct bonding of the copper layer and the ceramic substrate has been applied. This is to ensure uninhibited heat transfer and high thermal fatigue strength.

The relay has been designed for applications requiring large numbers of load cycles.

Power dissipation

The power dissipation for intermittent use is calculated according to the following formula:

$$I_{rms} = \sqrt{\frac{I_{ON}^2 \times t_{ON}}{t_{ON} + t_{OFF}}}$$

Ex: RA 24 50 -D 06:
Load current = 45 A
t_{ON} = 30 s
t_{OFF} = 15 s

$$I_{rms} = \sqrt{\frac{45^2 \times 30}{30 + 15}}$$

The rms current will be 36.7 A.

