

DATE	SYM	REVISION RECORD	AUTH.	DR.	CK.
1/16/01	-	ISSUED		NT	DG

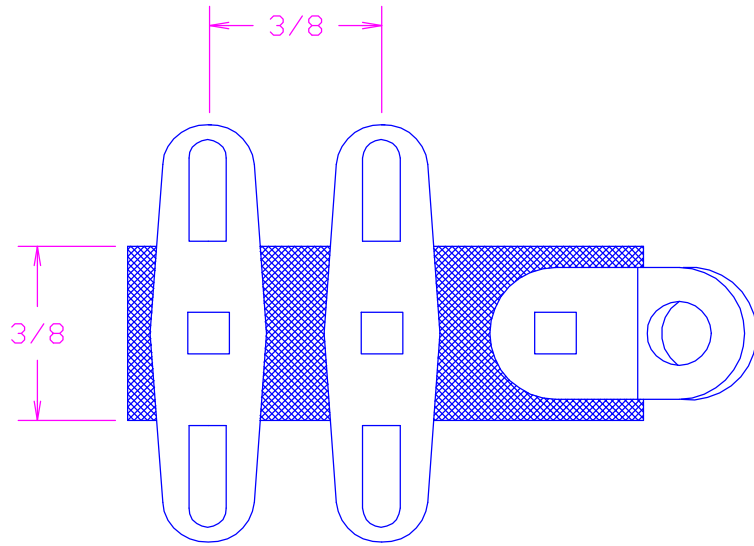

LUG: PLATED STEEL, SPACED 3/8" CENTER
 STRIP: XP PHENOLIC 3/8" WIDE x .062" THICK.
 MOUNT: .140 HOLE FOR #6 SCREW

ACTUAL SIZE

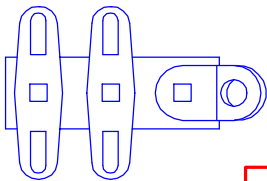

TOLERANCES (EXCEPT AS NOTED)	CONCORD		ELECTRONICS CORPORATION
DECIMAL ± .010	P/N	SCALE	30 GREAT JONES ST. NEW YORK N. Y. 10012
FRACTIONAL ± 1/64	TITLE "T" TYPE TERMINAL STRIPS		
ANGULAR ±	DATE 1/15/01	DRAWING NUMBER 707-5222	