

DOL Starters Type EXE0D



Plastic Enclosure to IP66

Installation Instructions Issue 10

06.012226; 10E 0808

1. Remove cover from starter.
2. Select and fit Overload (see ratings chart below).
3. Connect leads provided from - terminal 14 to Overload 95 and terminal A2 to Overload 96.
4. Check operating coil voltage and frequency.
5. Remove appropriate top/bottom knockouts. Attach conduit bushes to conduit.
6. Mount base and connect to bushes. If continuous grounding is required fit separate bonding strip
7. For on-site control circuit conversions see overleaf.
8. Connect cables and ensure that all terminations are tight.
9. When installed, set the Hand/Auto selector and adjust the current calibration to the desired value. (See below)
10. Replace cover and secure
11. Note: If an extra control device is required, see overleaf.

Ratings

Order references		Requires Overload	Overload rating Full load A		Approximate motor rating				Recommended max. fuse size for short circuit protection A		
Coil Voltages (50Hz)			min.	max.	400V/3PH AC3		230V/1PH AC3				
230V	400V			KW	hp	KW	hp				
122EXE0D-OL 1TVL300212E5099	124EXE0D-OL 1TVL300412E5099	TA25DU1.4 1SAZ211201R1023	1.0	1.4	0.37	0.55	0.07	0.09	4		
		TA25DU1.8 1SAZ211201R1025	1.3	1.8	0.55	0.75	0.1	0.125	10		
		TA25DU2.4 1SAZ211201R1028	1.7	2.4	0.75	1.0	0.18	0.25			
		TA25DU3.1 1SAZ211201R1031	2.2	3.1	1.1	1.5	0.25	0.33			
		182EXE0D-OL 1TVL300216E5099	184EXE0D-OL 1TVL300416E5099	TA25DU4.0 1SAZ211201R1033	2.8	4.0	1.5	2.0	0.37	0.5	20
				TA25DU6.5 1SAZ211201R1038	4.5	6.5	2.2	3.0	0.55	0.75	
				TA25DU11 1SAZ211201R1043	7.5	11.0	4.0	5.5	1.1	1.5	35
		TA25DU14 1SAZ211201R1045	10.0	14.0	5.5	7.5	1.5	2.0			
TA25DU19 1SAZ211201R1047	13.0	19.0	7.5	10.0	2.2	3.0					

Note: This product is not suitable for d.c. applications.

Terminal capacity

	Main	Auxiliary
Contactors	1 x 4mm ² or 2 x 2.5mm ²	1 x 4mm ² or 2 x 2.5mm ²
Overload	1 x 10mm ² or 2 x 6mm ²	2 x 2.5mm ²

Summary

A direct-on-line motor starter with ingress protection to IP66. Two-tone plastic enclosure with ABS lid and base.

Trip class 10 requirements IEC 947-4-1

1.05 x FLC	No tripping
1.2 x FLC	Trip within 2 hours
1.5 x FLC	Trip within 4 minutes
7.2 x FLC	Trip between 4s and 10s

NOTE: FLC = Full load current



Connection Data

Type 4 (400V coil)

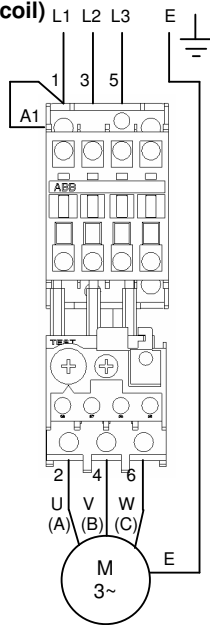

Type 2 (230V coil)

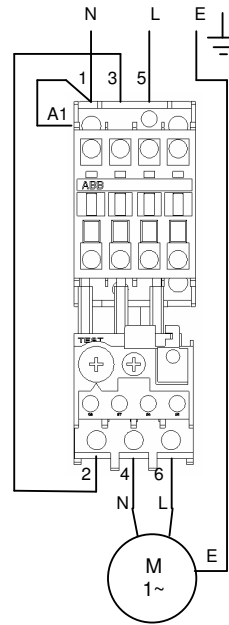
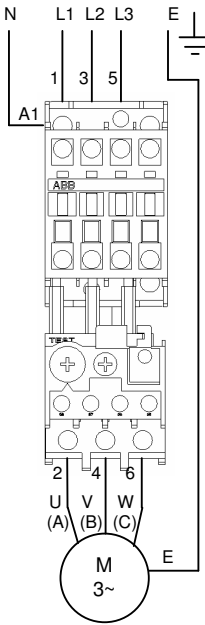

Note: For Single phase Operation link 1 to A1, 3 to 2 as shown.

Circuits

Standard circuit

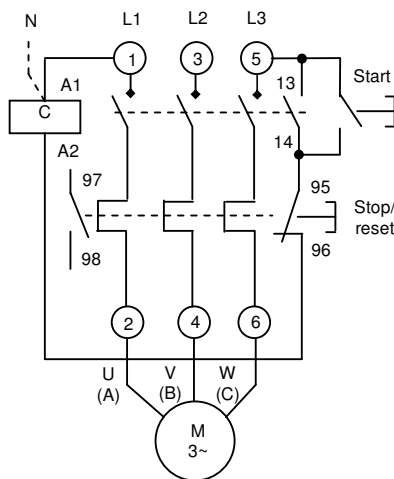

Special circuits

Line-to-line plus remote 3-wire control

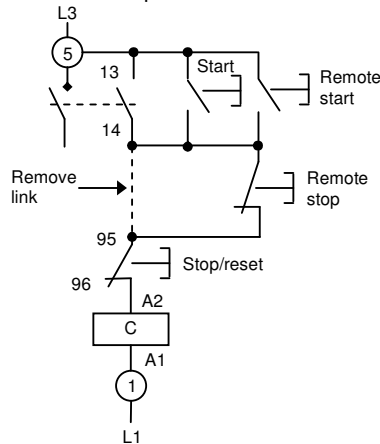

Two-wire controls

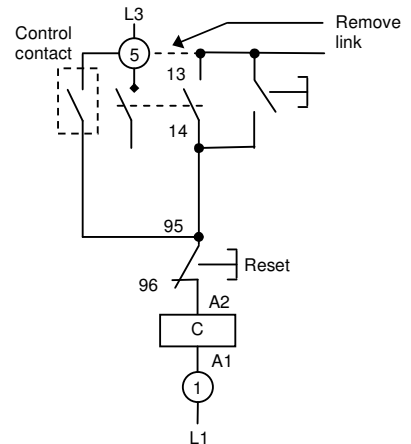

Fitting an extra control device

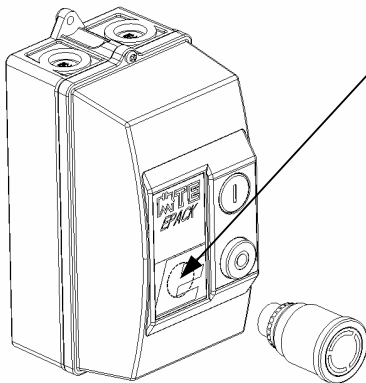

A knockout is provided in the lid of the EXE0 for an extra control device.

1. Remove lid of starter
2. Cut around serrated label insert and remove
3. Remove front 22mm knockout.
4. Fit control device kit.

Control device kits

ESPBKIT Emergency Stop (EN418):
Comprises 40mm E-stop button, n.c. contact block.

PLPBKIT Pilot Lamp (230v only):
Comprises Green compact LED 230v Pilot Lamp.

HAPBKIT 2 Position Switch:
Comprises compact 2 position switch 1 n.o + 1 n.c contacts.

N.B. Space is available to fit standard ABB top and side mounting auxiliary contact blocks.

Council of European Communities Directives: The products in this publication conform to relevant EEC Directives and EN Standards. Installation and use of such products must be carried out by competent, properly trained personnel, complying with any instructions supplied by ABB. Liability for improper incorporation, assembly, use, processing, storing or handling of goods remains the sole responsibility of the individual, or company carrying out such work. This publication is for information only. Whilst every care has been taken in the preparation of this leaflet, no liability is accepted for any consequence of its use. No licence to use any patent should be assumed. All dimensions are approximate only and subject to change without notice, as are other technical features resulting from continual development and improvement.